

TIPO TYPE TYP	A	A1	C	C1	D	D1	E	E1	F	J	L**	L1**	M	N	N°fori holes nr. N.trous Loch nr.	O	P	P1
SF150	210	165	155	105	95	145	10	10	130	115	10	397	440	1'gas	1	226	210	165
SF180	250	178	190	118	115	155	10	11,5	140	130	10	438	480	1'gas	2	271	250	178
SF230	298	200	235	135	135	172	14	14	174	156	12	496	541	1'gas	2	329	298	200
SF270	342	222	276	158	155	194	16	14	213	177	12	543	592	1'gas	2	375	342	222
SF300	428	278	340	198	195	250	19	14	248	199	13	666	709	1'gas	2	468	428	278
SF350*	580	332	476	220	180	300	20	16	290	240	15	839	876	1 1/2'gas	2	601	580	352
SF450*	715	425	570	285	215	370	35	27,5	338,5	338,5	22	1042	1097	1 1/2'gas	2	730	715	435

TIPO TYPE TYP	Q	Q1	R	R1	S	S1	ØT	N°fori holes nr. N.trous Loch nr.	T1	N°fori holes nr. N.trous Loch nr.	U**	V**	W	ØX	Y	Ø	Ø1	PESO WEIGHT POIDS GEWICHT
SF150	155	105	95	145	10	10	10	6	M8	6	286	405	88,5	24	7	43	49	50 Kg
SF180	190	118	115	155	10	11,5	10	6	M8	6	286	416	95	24	7,5	54	61	59 Kg
SF230	238	135	135	172	14	14	10	6	M8	6	352	512	120	28	9	64	71	92 Kg
SF270	276	148	155	194	16	14	12	6	M10	6	352	537	140	28	10	74	81	130 Kg
SF300	340	198	195	250	19	14	13	6	M12	6	383	593	160	34	14	96	103	185 Kg
SF350*	470	238	180	300	20	26	14	8	M12	8	404	634	185	42	14	118	127	312 Kg
SF450*	570	285	215	185	35	32,5	15	8	M14	10	503	798	240	54	18	150	159	575 Kg

* Solo trasmissione diretta / Direct drive only / Transmission direct uniquement / Direkter Antrieb

** Queste misure possono variare in base al tipo di motoriduttore adottato / These measures might change according to the type of the gearmotor
Ces dimensions peuvent changer selon le moto-réducteur employée / Diese Abmessungen können nach den angewendeten Getriebemotor ändern

Ci riserviamo di modificare le misure senza preavviso. We reserve the right to change any dimension without notice. Nous reservons de modifier les mesures sans préavis. Wir behalten uns das Recht vor die im Katalog angegebenen Abmessungen ohne Voranmeldung zu ändern.

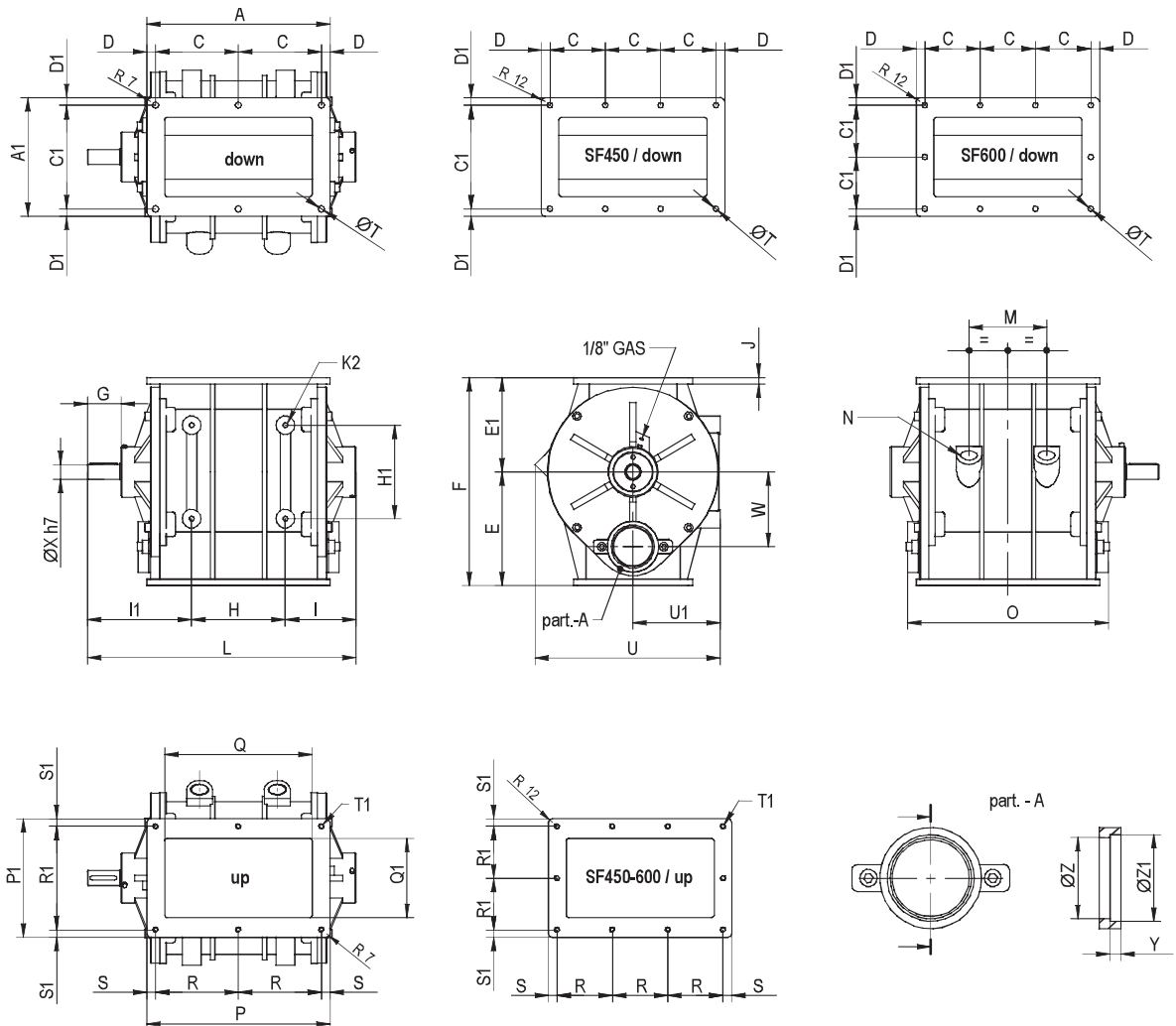

TIPO TYPE TYP	A	A1	C	C1	D	D1	E	E1	F	G	H	H1	I	I1	J	K2	L	M	N	N°fori holes nr. N.trous Loch nr.
SF150	210	165	95	145	10	10	130	115	245	57	116	105	90	147	10	M8	353	--	1'gas	1
SF180	250	178	115	155	10	11,5	140	130	270	57	120	120	107,5	164,5	10	M8	392	119	1'gas	2
SF230	298	200	135	172	14	14	174	156	330	62	150	150	119,5	181,5	12	M10	451	131	1'gas	2
SF270	342	222	155	194	16	14	213	177	390	62	175	175	132	194	12	M10	501	145	1'gas	2
SF300	428	278	195	250	19	14	248	199	447	62	200	200	157	219	13	M12	576	182	1'gas	2
SF350	580	332	180	300	20	16	290	240	530	92	320	220	167,5	259,5	15	M12	747	249	1 1/2'gas	2
SF450	715	425	215	370	35	27,5	368	309	677	103	400	300	210	313	22	M14	923	270	1 1/2'gas	2
SF600	840	530	266	444	21	21	446	384	830	100	300	300	512,5	312,5	25	M14	1125	360	1 1/2'gas	2

TIPO TYPE TYP	O	P	P1	Q	Q1	R	R1	S	S1	T	Ø	N°fori holes nr. N.trous Loch nr.	T1	N°fori holes nr. N.trous Loch nr.	U	U1	W	Ø	Y	Ø	Ø1
SF150	226	210	165	155	105	95	145	10	10	10	6	M8	6	225	105	88,5	24	7	43	49	
SF180	271	250	178	190	118	115	155	10	11,5	10	6	M8	6	250	118	95	24	7,5	54	61	
SF230	329	298	200	238	135	135	172	14	14	10	6	M8	6	310	146	120	28	9	64	71	
SF270	375	342	222	276	148	155	194	16	14	12	6	M10	6	350	166	140	28	10	74	81	
SF300	468	428	278	340	198	195	250	19	14	13	6	M12	6	400	188	160	34	14	96	103	
SF350	601	580	352	470	238	180	300	20	26	14	8	M12	8	450	220	185	42	14	118	127	
SF450	730	715	435	570	285	215	385	35	32,5	15	8	M14	10	580	285	240	54	18	150	159	
SF600	897	840	530	635	356	266	444	21	21	18	10	M16	10	690	350	280	60	18	186	195	

Ci riserviamo di modificare le misure senza preavviso. We reserve the right to change any dimension without notice. Nous reservons de modifier les mesures sans préavis. Wir behalten uns das Recht vor die im Katalog angegebenen Abmessungen ohne Voranmeldung zu ändern.

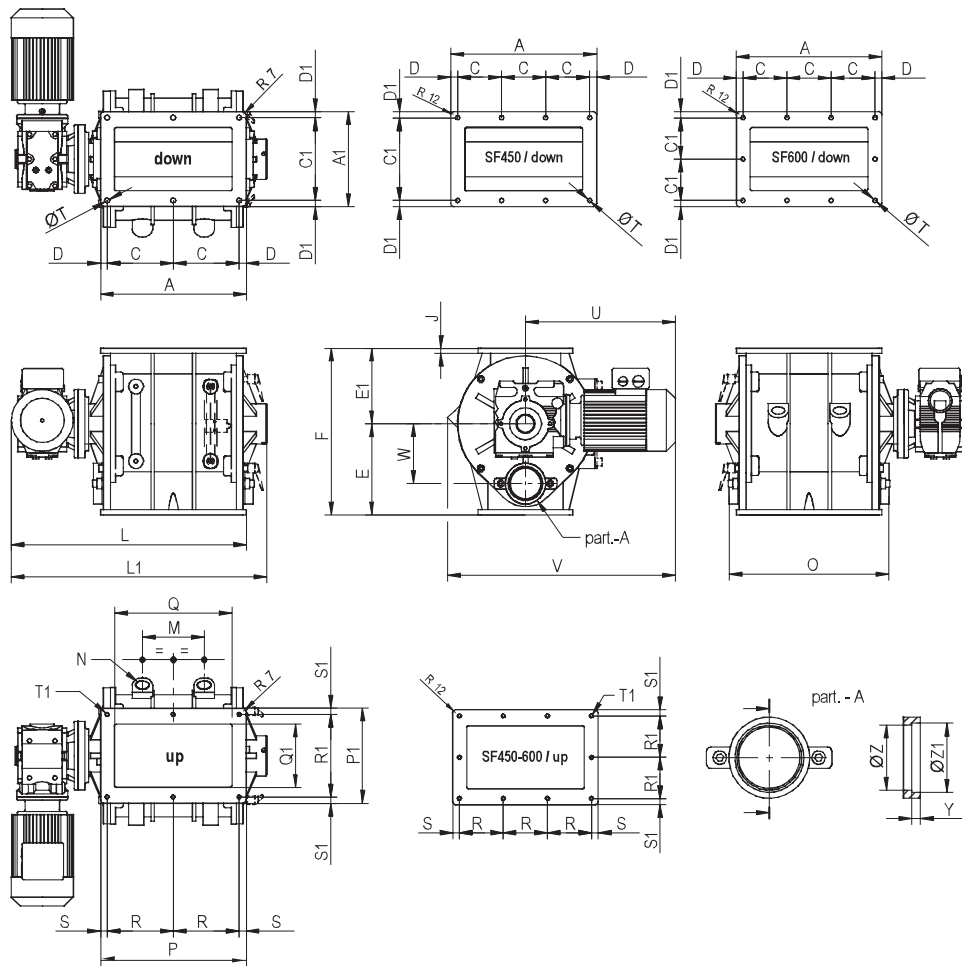

TIPO TYPE TYP	A	A1	C	C1	D	D1	E	E1	F	J	L**	L1**	M	N	N°fori holes nr. N.trous Loch nr.	O	P	P1
SF150	210	165	155	105	95	145	10	10	130	115	10	397	440	1'gas	1	226	210	165
SF180	250	178	190	118	115	155	10	11,5	140	130	10	438	480	1'gas	2	271	250	178
SF230	298	200	235	135	135	172	14	14	174	156	12	496	541	1'gas	2	329	298	200
SF270	342	222	276	158	155	194	16	14	213	177	12	543	592	1'gas	2	375	342	222
SF300	428	278	340	198	195	250	19	14	248	199	13	666	709	1'gas	2	468	428	278
SF350*	580	332	476	220	180	300	20	16	290	240	15	839	876	1 1/2'gas	2	601	580	352
SF450*	715	425	570	285	215	370	35	27,5	338,5	338,5	22	1042	1097	1 1/2'gas	2	730	715	435

TIPO TYPE TYP	Q	Q1	R	R1	S	S1	ØT	N°fori holes nr. N.trous Loch nr.	T1	N°fori holes nr. N.trous Loch nr.	U**	V**	W	ØK	Y	Ø	Ø1	PESO WEIGHT POIDS GEWICHT
SF150	155	105	95	145	10	10	10	6	M8	6	286	405	88,5	24	7	43	49	50 Kg
SF180	190	118	115	155	10	11,5	10	6	M8	6	286	416	95	24	7,5	54	61	59 Kg
SF230	238	135	135	172	14	14	10	6	M8	6	352	512	120	28	9	64	71	92 Kg
SF270	276	148	155	194	16	14	12	6	M10	6	352	537	140	28	10	74	81	130 Kg
SF300	340	198	195	250	19	14	13	6	M12	6	383	593	160	34	14	96	103	185 Kg
SF350*	470	238	180	300	20	26	14	8	M12	8	404	634	185	42	14	118	127	312 Kg
SF450*	570	285	215	185	35	32,5	15	8	M14	10	503	798	240	54	18	150	159	575 Kg

* Solo trasmissione diretta / Direct drive only / Transmission direct uniquement / Direkter Antrieb

** Queste misure possono variare in base al tipo di motoriduttore adottato / These measures might change according to the type of the gearmotor
Ces dimensions peuvent changer selon le moto-réducteur employée / Diese Abmessungen können nach den angewendeten Getriebemotor ändern

Ci riserviamo di modificare le misure senza preavviso. We reserve the right to change any dimension without notice. Nous reservons de modifier les mesures sans préavis. Wir behalten uns das Recht vor die im Katalog angegebenen Abmessungen ohne Voranmeldung zu ändern.